

0603 1% Chip Resistors

Introduction:

Chip resistors consist of a deposited resistive paste on ceramic body and two wrapping end of the resistor to wave soldering.

Features:

- The resistive layer is covered with a protective coating to assure mechanical and environmental integrity.
- Excellent mechanical strength and electrical stability due to special electrode construction.
- Accurate and uniformed physical dimensions.

Dimensions:

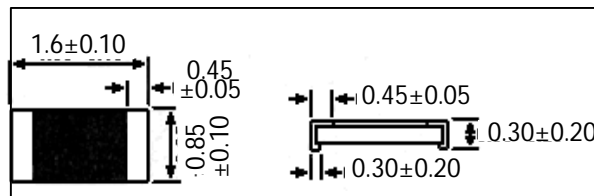

Construction:

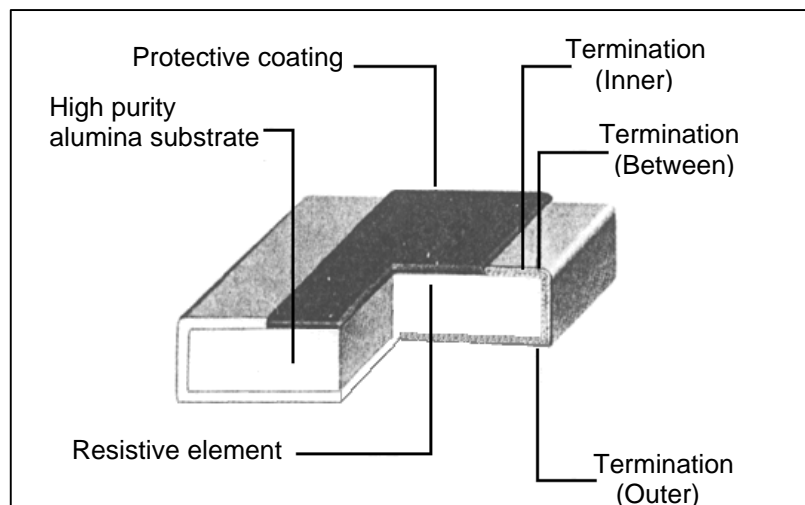

Ratings:

Power rating	
Normal:	1/16W
Upgrade:	1/10W
Max. working voltage:	50V
Max. overload voltage:	100V
Operating temperature range:	-55°C to +125°C
Resistance tolerance:	1%

Power derating curve:

For resistors operated in ambient temperatures above 70°C, power rating must be derated in accordance with the curve below.

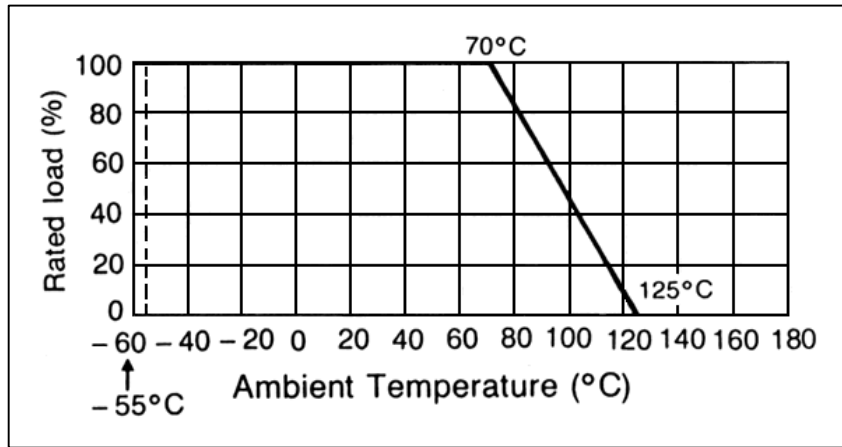

Characteristics:

Requirements	Characteristics	Test method	
		JIS C 5202	E1AJ 2690
Temp. coefficient (ppm/°C):	< ± 300	5.2	-
Terminal strength:	± (1% + 0.05Ω)	-	6.5
	Over 1Kg/mm ²	-	-
Resistance to soldering heat:	± (1% + 0.05Ω)	6.4 270°C/10 sec.	-
Short time overload:	± (1% + 0.05Ω)	5.5A	-
Intermittent overload:	± (2% + 0.05Ω)	5.8	-
Temperature cycling:	± (2% + 0.2Ω)	-	6.8
Load life:	± (3% + 0.1Ω)	7.10 1,000Hr	-
Moisture resistance:	± (2% + 0.05Ω)	7.9 1,000Hr	-
Electrode solderability:	> 95% coverage	6.5 230°C/5 sec.	-
Insulation resistance:	10MΩ min.	-	-
Dielectric withstanding voltage:	500V/minute	-	-
Vibration:	± 1%	-	-

Taping specifications:

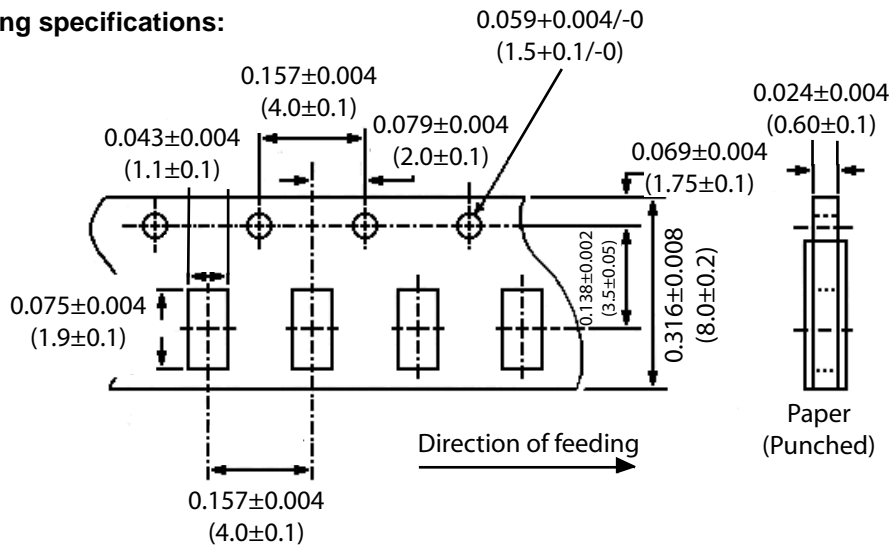

Reel dimensions:

